



**Benha University**

*Prof. Mohamed Ahmed Ebrahim*

**Benha University**  
**Faculty of Engineering at Shoubra**  
**Electrical Engineering Dept.**



# ***Energy Storage & Transmission***

*By*



*Associate Prof. / Mohamed Ahmed Ebrahim Mohamed*

E-mail: [mohamedahmed\\_en@yahoo.com](mailto:mohamedahmed_en@yahoo.com)

[mohamed.mohamed@feng.bu.edu.eg](mailto:mohamed.mohamed@feng.bu.edu.eg)

Web site: <http://bu.edu.eg/staff/mohamedmohamed033>





*Lecture (4)*  
*11-03 - 2019*





*Units of Energy and Power  
and  
Important Constants*

*Prof. Mohamed Ahmed Ebrahim*

# Work, Energy, and Power



**“It is important to realize that in physics today, we have no knowledge of what energy is.” - R.P. Feynman**

# The Launch of a Rocket

**F = Force**

**D = Direction**

LIFTOFF!

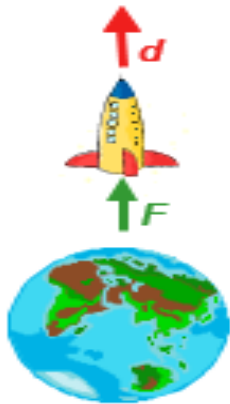

***F and d  
are parallel***

**rocket gains  
potential energy**

SPEED!



***F and d  
are parallel***

**rocket gains  
potential energy**

ORBIT!

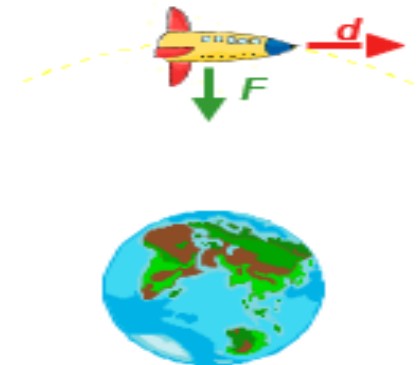

***F and d  
are perpendicular***

**rocket has constant  
energy (circular  
orbit)**

# Driving a Car

## SPEED UP

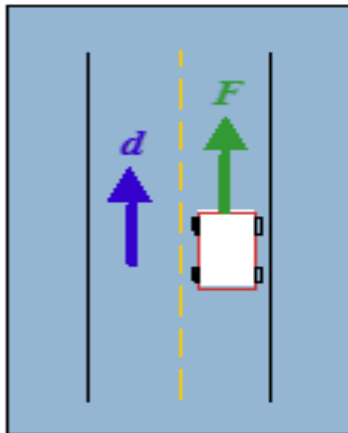

$F$  and  $d$   
are parallel

car gains  
kinetic  
energy

## SLOW DOWN

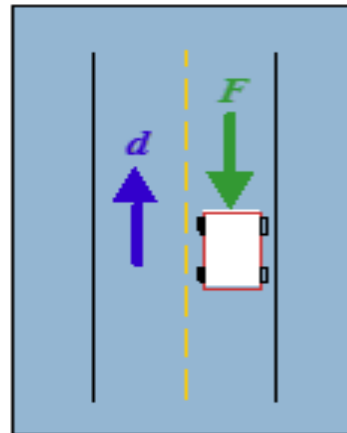

$F$  and  $d$   
are opposite

car loses  
kinetic  
energy

## 'ROUND A CORNER

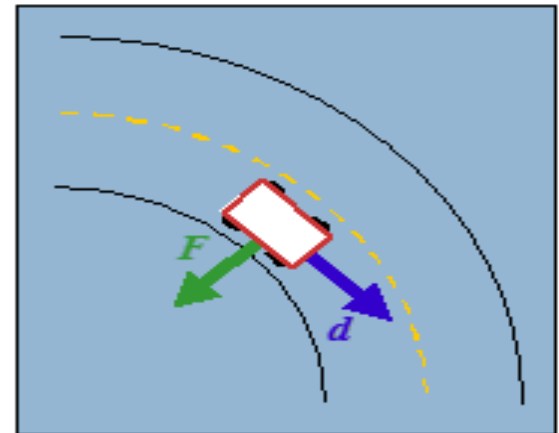

$F$  and  $d$   
are perpendicular

car maintains  
kinetic  
energy

# Work and Energy

- Work and Energy are defined in a “circular” manner, meaning they are each defined based on the other.
- **Work**
  - Change in the energy of an object, or system (noun).
  - Act of transferring energy (verb).
- **Energy**
  - A measure of a change in the condition of matter.
  - Energy is transferred by doing work on a system.
  - There is no such thing as pure energy. Only a transfer of energy, or a transformation of energy has meaning.



# Work

□ **Work depends on three things:**

1. force on an object.
2. displacement of an object.
3. angle between the force and displacement (force must cause the displacement).

$$W = Fd \cos \theta$$

□ **Units**

$$1 \text{ joule} = 1 \text{ newton} \times 1 \text{ meter} = 1 \text{ N} \cdot \text{m}$$

- work is a scalar quantity, but can be positive, negative, or zero because it represents the amount of energy change.

**work is positive when  $0^\circ < \theta < 90^\circ$**

**work is negative when  $90^\circ < \theta < 180^\circ$**

**work is zero when  $\theta = 0^\circ$**

# Power

- Power is the rate at which work done (or energy is used)

$$P = \frac{W}{t}$$

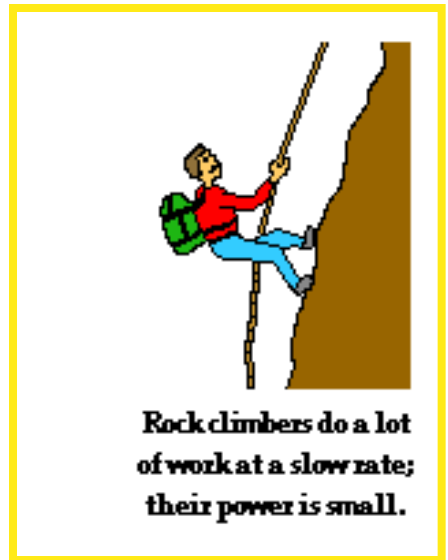

- Units

$$1 \text{ watt} = \frac{1 \text{ joule}}{1 \text{ second}} = 1 \frac{\text{J}}{\text{s}}$$

$$P = \frac{W}{t} = \frac{Fd \cos \theta}{t} = Fv$$

# Potential Energy

- Potential energy is the energy of position of matter.
- **gravitational potential:** depends on the position of mass in a gravitational field.

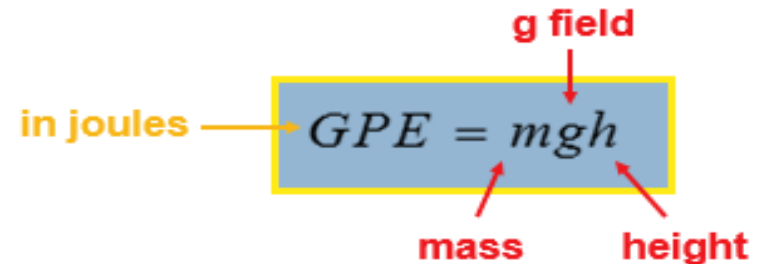

The diagram shows the equation  $GPE = mgh$  enclosed in a blue box with a yellow border. A yellow arrow points from the text "in joules" to the left side of the box. Three red arrows point from labels to variables in the equation: "g field" points to 'g', "mass" points to 'm', and "height" points to 'h'.

in joules →  $GPE = mgh$

g field  
mass height

- **elastic potential:** depends on the position of mass on an atomic scale

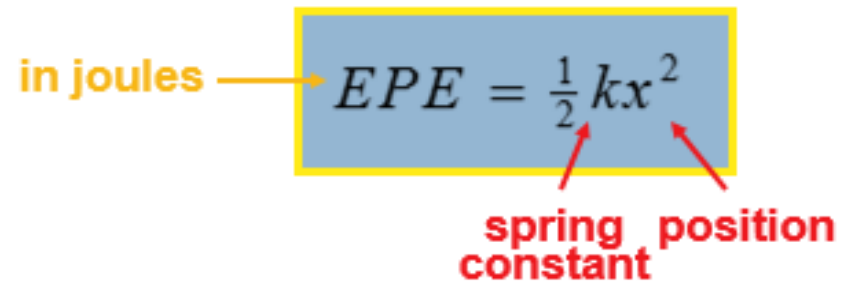

The diagram shows the equation  $EPE = \frac{1}{2}kx^2$  enclosed in a blue box with a yellow border. A yellow arrow points from the text "in joules" to the left side of the box. Two red arrows point from labels to variables in the equation: "spring constant" points to 'k' and "position" points to 'x'.

in joules →  $EPE = \frac{1}{2}kx^2$

spring constant position

# Kinetic Energy

- Kinetic energy is the energy of motion of matter.
- **kinetic energy:** depends on the motion of macroscopic objects (e.g. a car in motion) moving linearly.

$$KE = \frac{1}{2}mv^2$$

in joules mass velocity

- **thermal energy:** depends on the motion of microscopic objects (e.g. atomic vibrations). Often this energy is called heat.

in joules

$$TE = F_k d$$

friction distance

# Conservation of Mechanical Energy

- **Mechanical energy is the sum of kinetic and potential energy.**

$$ME = KE + PE$$

- **Conservative forces (gravity, spring force) keep mechanical energy constant.**
- **Potential and kinetic energy may change, but the total mechanical energy does not change.**

*Conservation of Energy  
and  
Energy conversion techniques*

*Prof. Mohamed Ahmed Ebrahim*

# Types of Energy

## ■ RENEWABLE ENERGY:

- Renewable energy can be generated continuously practically without decay of source.
- **Ex:** Solar energy, Wind energy, Geothermal energy, Hydro energy.

## ■ NON-RENEWABLE ENERGY:

- Non-renewable energy is energy that comes from the ground and is not replaced in a relatively short amount of time.
- **Ex:** energy generated from combustion of fossil fuels, coal, gas.

# Renewable Energy

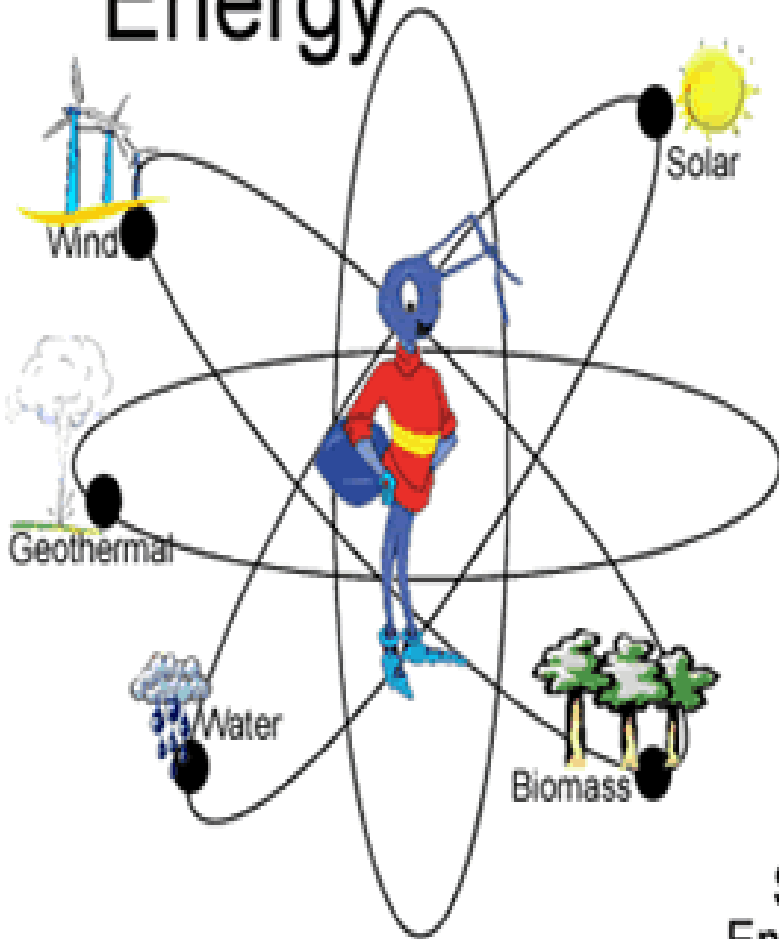

# Non-Renewable Energy

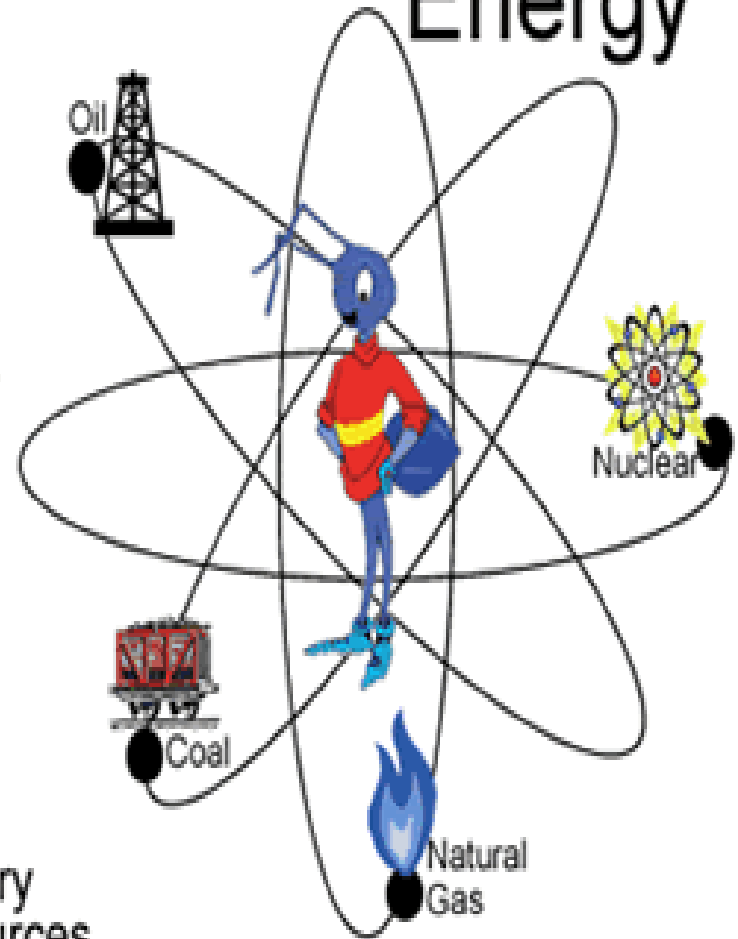

Secondary Energy Sources



# Electricity generation and population growth

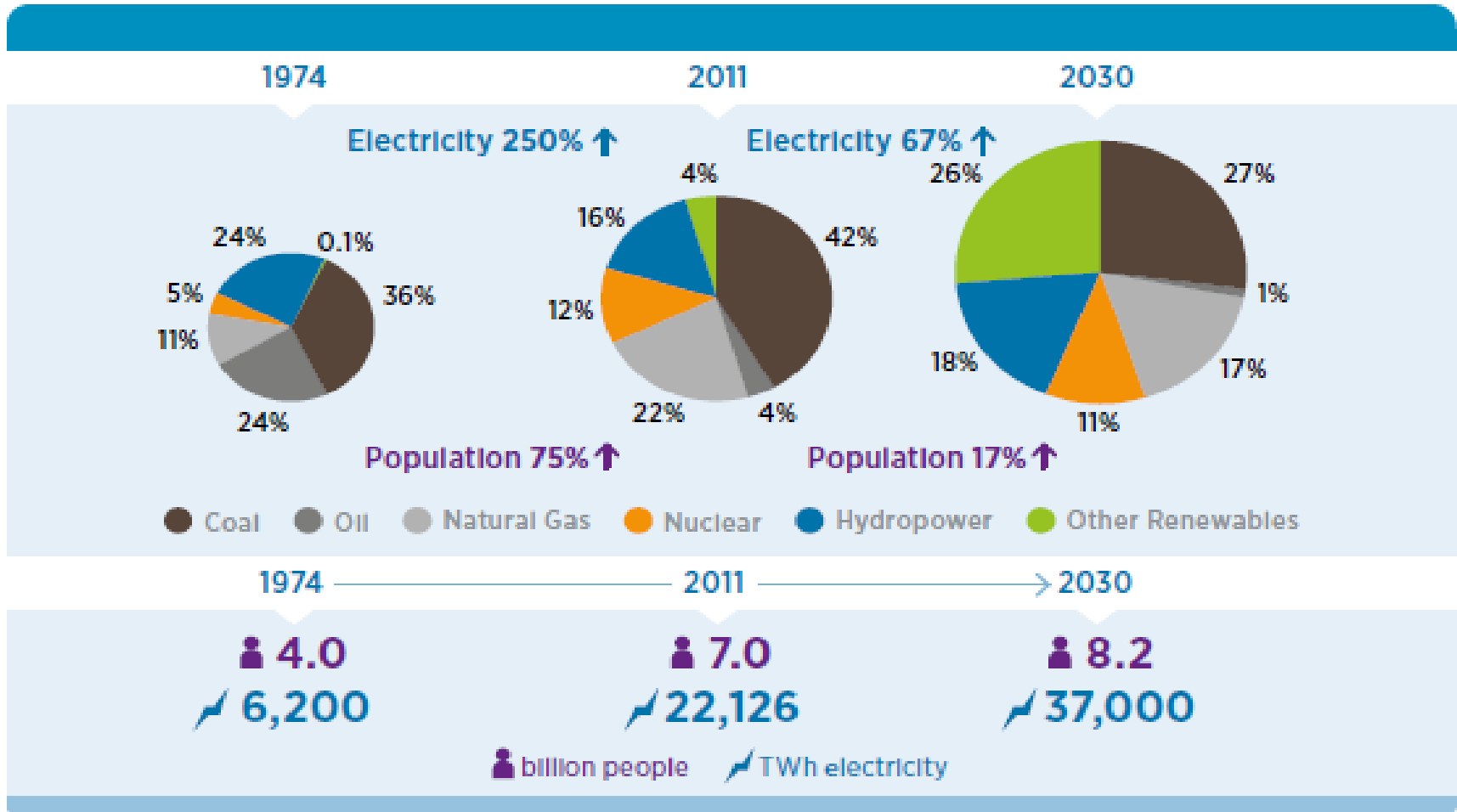

# Population vs Energy

Region/ Country/ Economy	Popu- lation (million)	GDP (billion 2005 USD)	GDP (PPP) (billion 2005 USD)	Energy prod. (Mtoe)	Net imports (Mtoe)	TPES (Mtoe)	Elec. cons. <sup>(a)</sup> (TWh)	CO <sub>2</sub> emissions <sup>(b)</sup> (Mt of CO <sub>2</sub> )
World	7 037	54 588	82 901	13 461	-	13 371 <sup>(c)</sup>	20 915	31 734 <sup>(d)</sup>
OECD	1 254	39 490	39 202	3 869	1 543	5 250	10 145	12 146
Middle East	213	1 430	4 184	1 796	-1 091	681	790	1 647
Dem. Rep. of Congo	65.71	10.81	26.42	20.94	-0.22	20.56	7.37	2.42
Egypt	80.72	125.90	768.85	82.05	-3.58	78.21	145.66	196.85
Ethiopia	91.73	24.66	99.62	43.04	2.75	45.49	5.30	7.93
Germany	81.92	3 073.86	2 851.34	123.38	199.56	312.53	584.71	755.27
Islamic Rep. of Iran	76.42	245.23	1 053.29	302.90	-82.66	219.59	210.35	532.15
Poland	38.54	407.64	705.63	71.43	30.92	97.85	148.42	293.77

# Estimated Renewable Energy Share of Global Electricity Production, End-2017

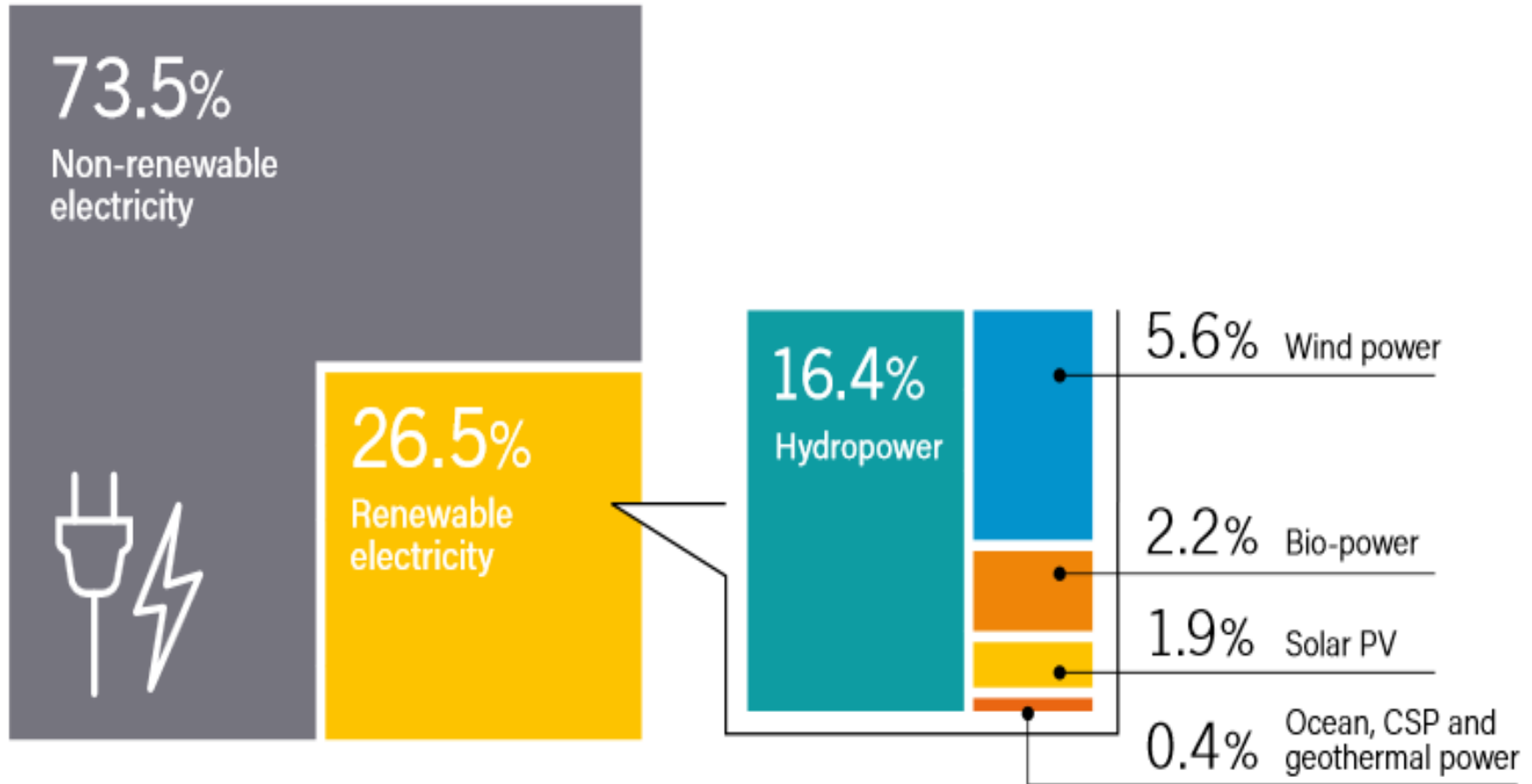

# Renewable Power Capacities\* in World, EU-28, and Top 6 Countries, 2017

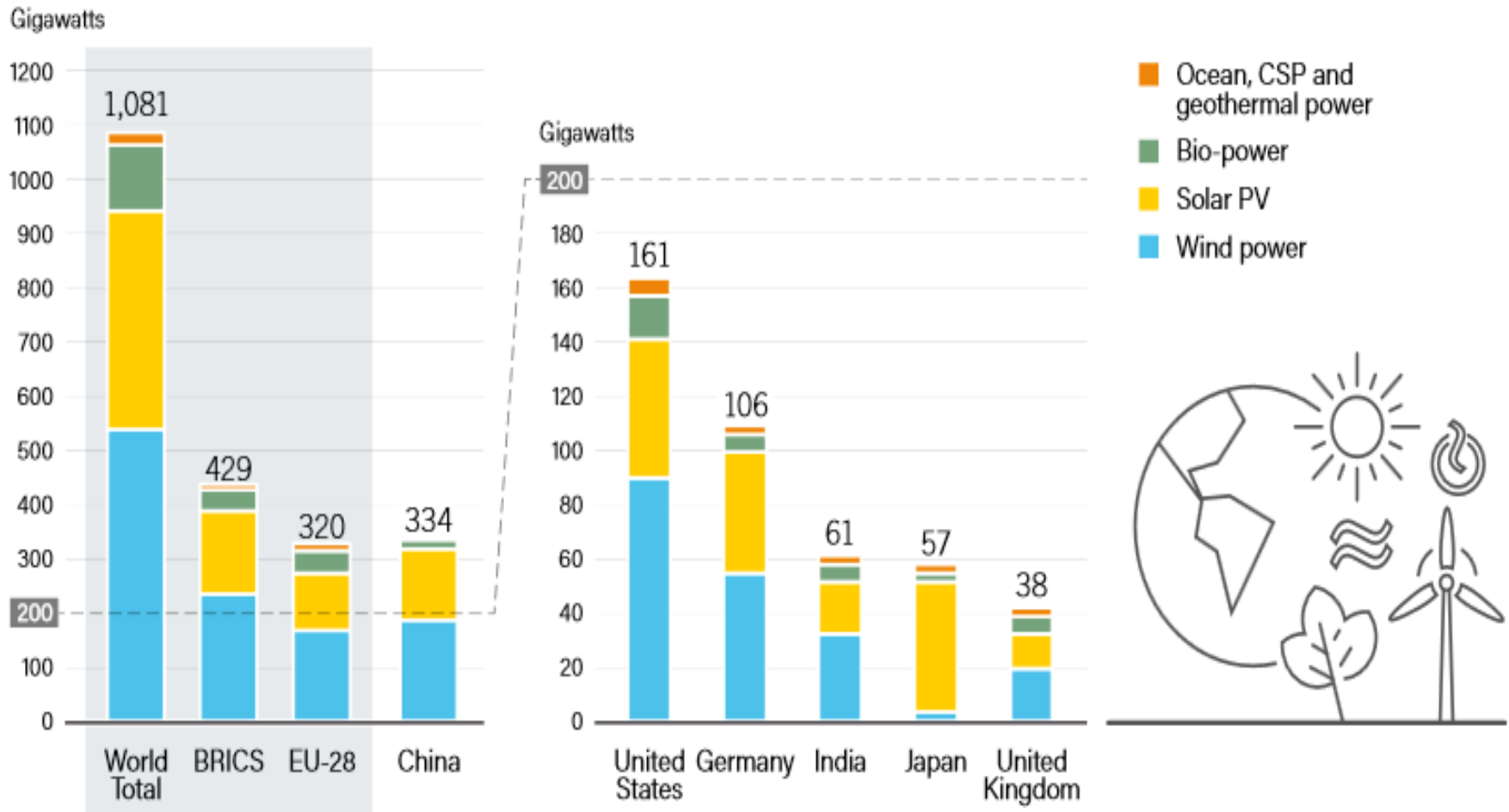

# Why to conserve it ?



- We have limited resources available on earth.
- Our demands are continuously increasing day by day.
- It is possible that someday most of the non-renewable resources will be exhausted and we will have to switch over to alternate energy.

We save our money when we save energy.



We reduce pollution when we save energy.



We save our energy when we save energy.



# What we can do ?

- **RECYCLE:** compositing waste materials into new products to prevent waste of potentially useful materials.
- **Turn off** all electronic devices that are not in use. Not only turn them off but try to remember to unplug them. You will be surprised how much you will save with this simple step!
- **Replace** old light bulbs with energy saving fluorescent bulbs. They may cost more, but will save you much more in the long run.

# How will it help ?



- **Let's Take an simple example :**

- assume electricity is available for a 100 watt bulb is used for 8 hrs a day then:
- If we replace a 100 watt bulb with 22 watt CFL ,
- The annual saving would be:
- Power saved :  $100W - 22W = 78W$



# *1. The Concept of Storage*

*Why do we need it?*

# *2. Electricity generation, transmission and storage*

# Energy Storage System (ESS)

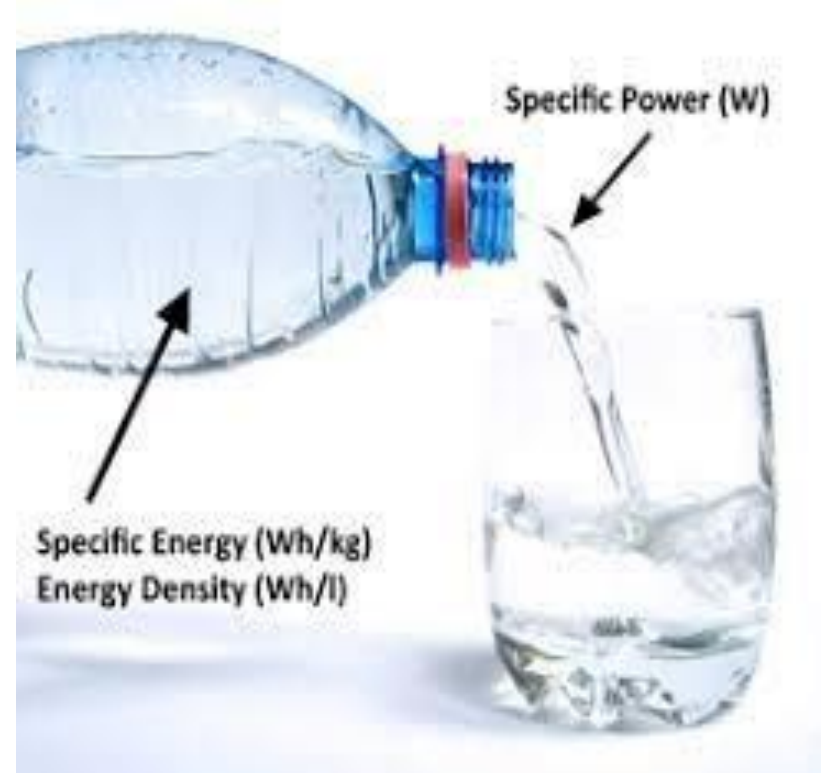

# Energy Storage System (ESS) Concept

- ❑ Energy storage devices are “charged” when they absorb energy, either directly from renewable generation devices or indirectly from the electricity grid.
- ❑ They “discharge” when they deliver the stored energy back into the grid.
- ❑ Charge and discharge normally require power conversion devices, to transform electrical energy (AC or DC) into a different form of electrical, thermal, mechanical or chemical energy.

# ESS helps grid system operators maintain constant frequency

- Energy storage based on lithium-ion battery (LIB) provides reliable and fast frequency response without being subject to fuel price and with zero emissions.

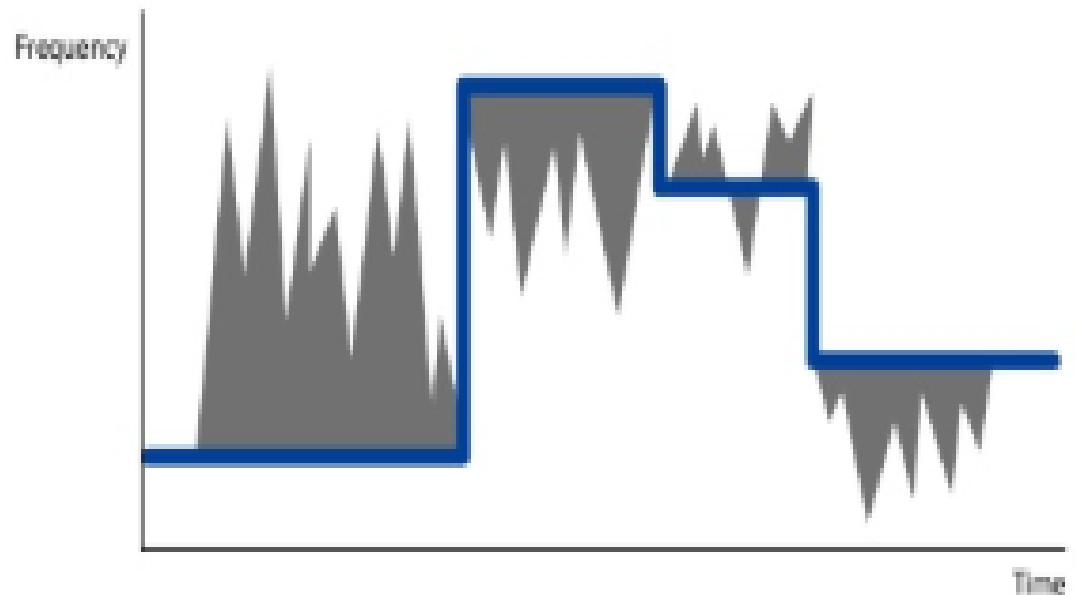

# ESS can be used for curtailment of electricity from renewable energy sources

- Due to transmission constraints, currently, ever increasing portion of wind generation is being curtailed.
- Energy storage is the option for reducing renewable power curtailment, relieving transmission congestion, and achieving full utilization of renewable energy sources.



- ESS can be used to defer transmission and distribution network (T & D) upgrades and investment.
- Using energy storage, upgrade to transmission and distribution networks can be deferred by smart management of the local peak demands.
- Transmission support.
- Transmission congestion relief.
- Area / Frequency regulation.

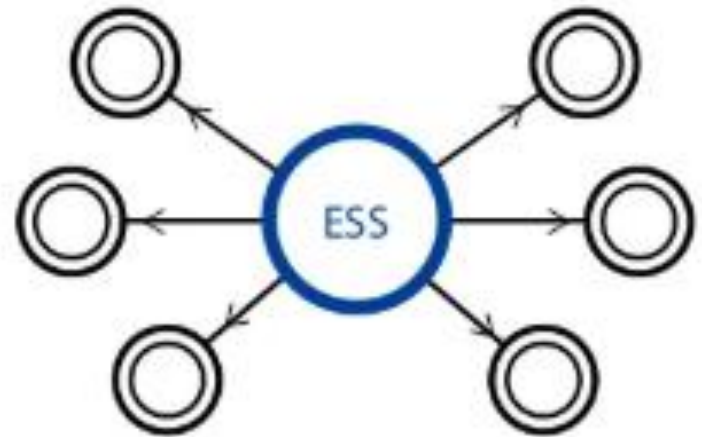

# ESS enables commercial & residential owners to cut energy costs

- Electricity stored during off-peak time can be used during no-peak hours so that home/commercial owners can cut peak demand and electricity cost.
- ESS integrated with PV can maximize consumption of solar energy by using electricity stored off-peak.
- Energy cost saving.
- Demand management.
- Self consumption of solar power.

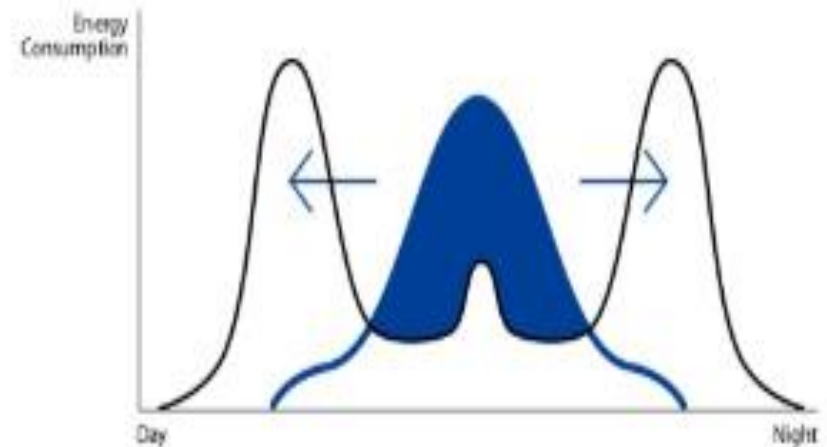

# Energy Storage Technologies: An overview of possible applications

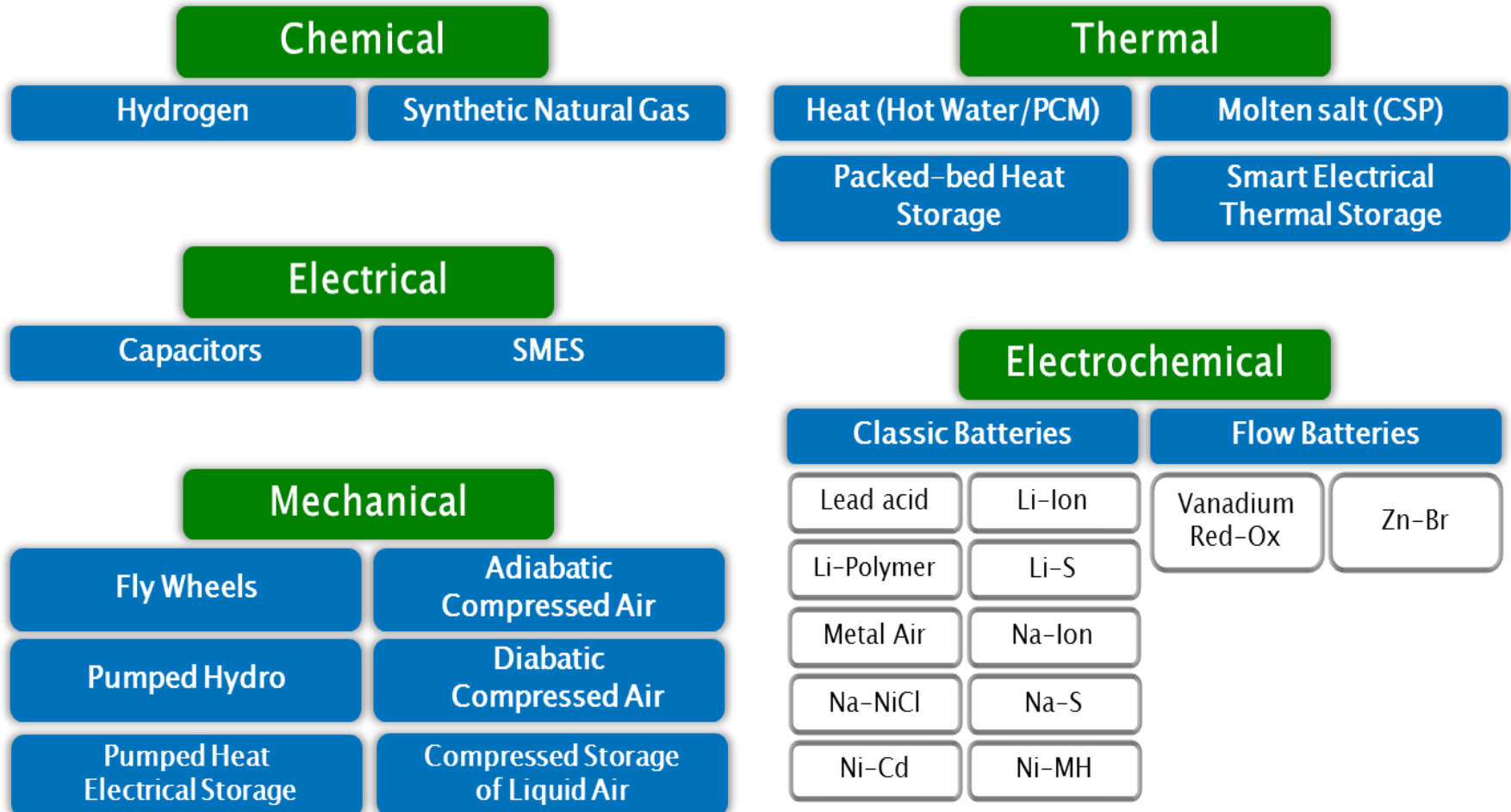



- Some technologies such as pumped hydro storage, compressed air energy storage, hydrogen and thermal storage are characterised by their ability to store energy over time (several hours)
- Others, e.g. batteries and flywheels, are characterised by their ability to deliver power very fast

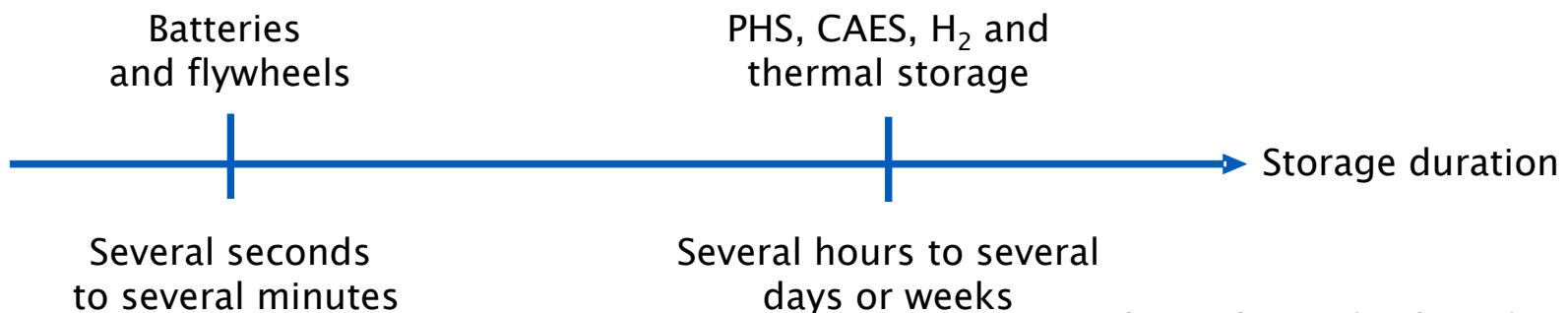

- For Renewable Energy Sources generation in specific, energy storage is well suited to:

**Generation**

**Renewable**

Distributed Generation flexibility

Capacity firming

Limitation of upstream perturbations

Curtailement minimisation

# Challenge of ESS

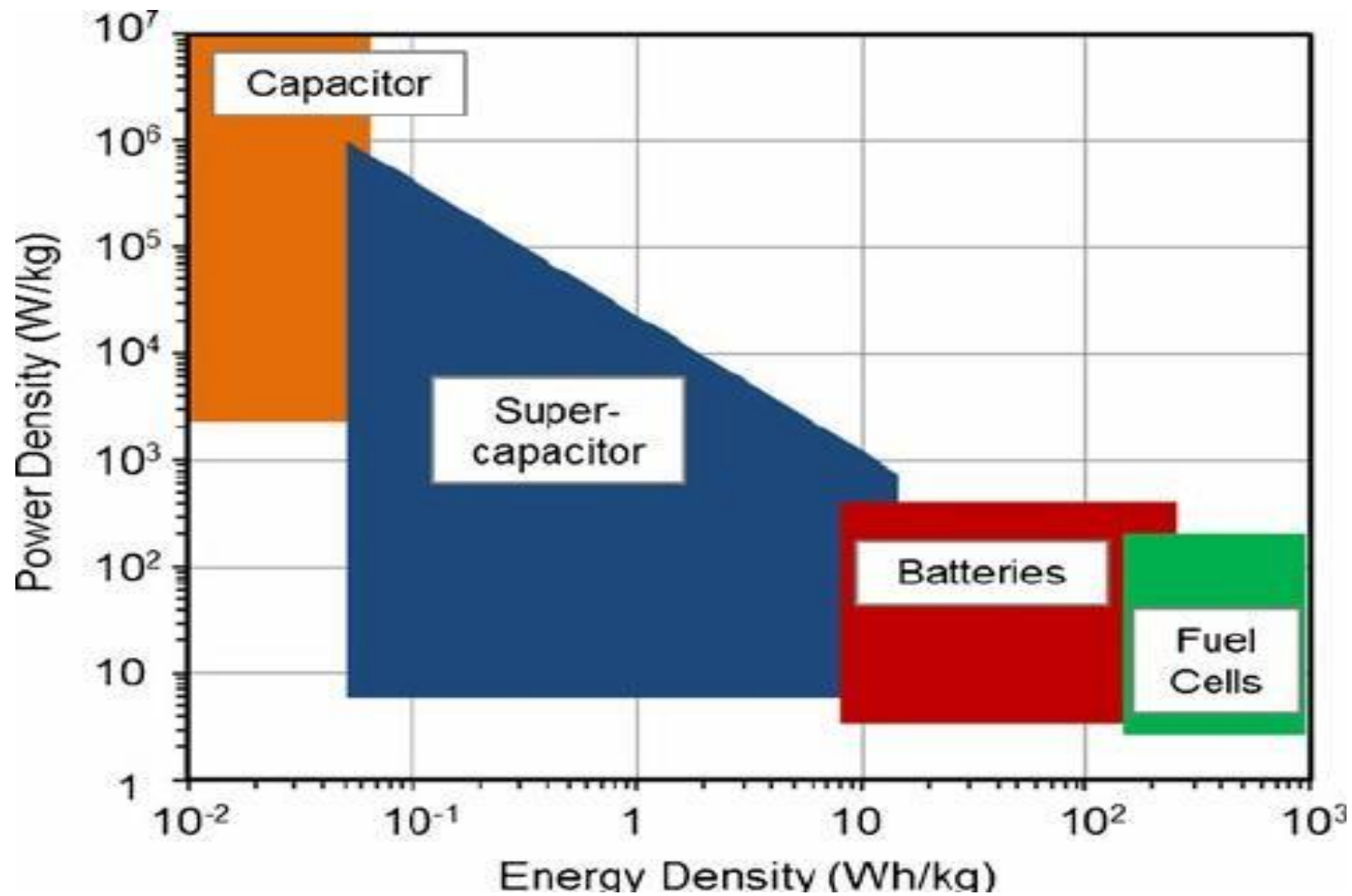

# Importance of ESS...

1. Thrust for Renewable Energy sources
2. Variable outputs
3. Energy Buffering
4. Importance in the present context
5. new technologies and devices

# Different Types of ESS...

ESS can be classified as:-

1. Mechanical Energy Storage.
2. Magnetic Energy Storage.
3. Electrochemical Energy Storage (batteries, flow cells).
4. Chemical Energy Storage (hydrogen, methane, gasoline, coal, oil)

# 1. Mechanical Energy Storage

## Fly Wheels

- **Principle:** Energy is stored in the form of Mechanical Energy.
- Light weight fiber composite materials are used to increase efficiency.
- Energy density  
 $=0.05\text{MJ/Kg}$ ,  $\eta=0.8$

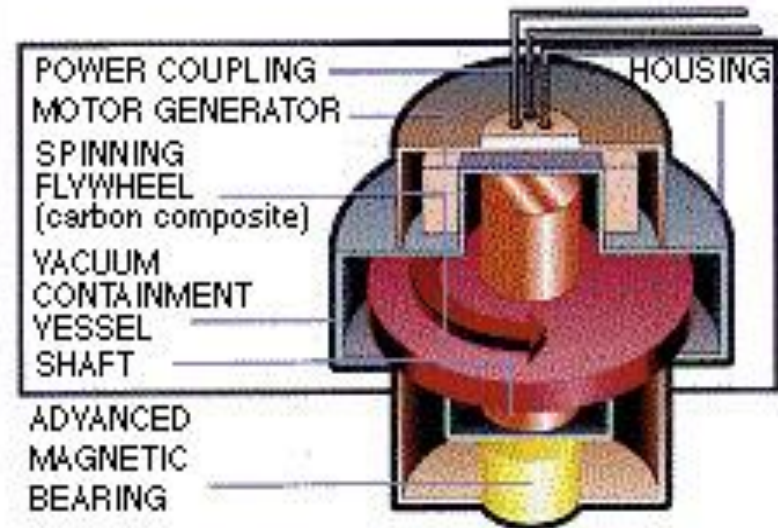

- The Energy Density is defined as the Energy per unit mass:

$$\frac{E}{m} = \frac{1}{2} V^2 = \frac{\sigma}{\rho}$$

- Where,

**V** is the circular velocity of the flywheel

**σ** is the specific strength of a material

**ρ** is the density of the material

# Advantages and disadvantages:

- Very compact when compared to other energy storage systems.
- Flywheels are used for starting and braking locomotives.
- A flywheel is preferred due to light weight and high energy capacity.
- It is not economical as it had a limited amount of charge/discharge cycle.



## 2. Magnetic Energy Storage

### Super capacitor

- Use of thin film polymers for the dielectric layer
- Carbon nanotubes and polymers are practical for super capacitors
- In future - carbon nanotubes with ceramics
- Reduce the effect of fluctuations
- Longer life time which reduces maintenance costs

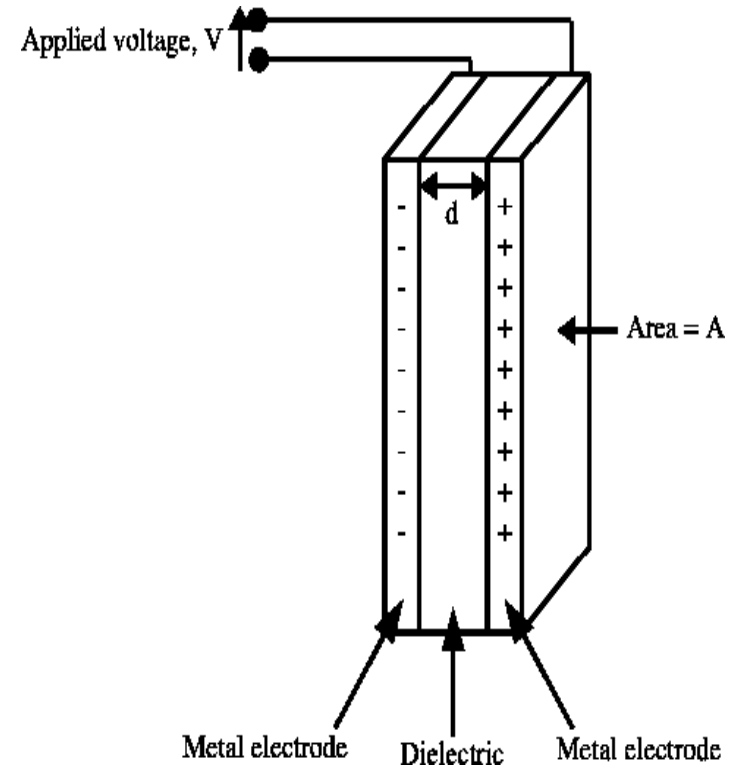

# 3. Electrochemical Storage

## Types of Batteries:

1. Small Capacities
2. Lead-Acid Batteries
  - They use a chemical reaction to do work on charge and produce a voltage between their output terminals.
  - Energy density is 0.6 MJ/Kg.
  - Efficiency of the cell is only 15%
3. Large Scale

# Working of a Lead acid Battery

Electrode connected  
to spongy lead plates

Electrode connected  
to lead dioxide

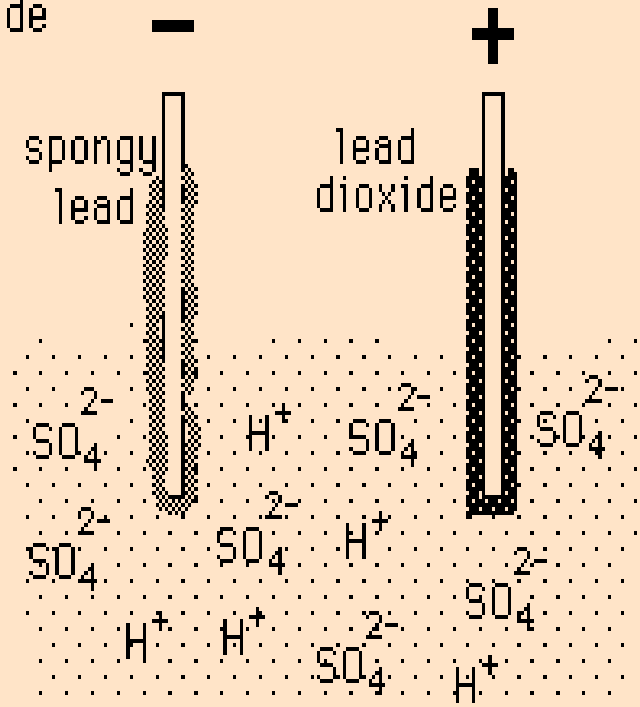
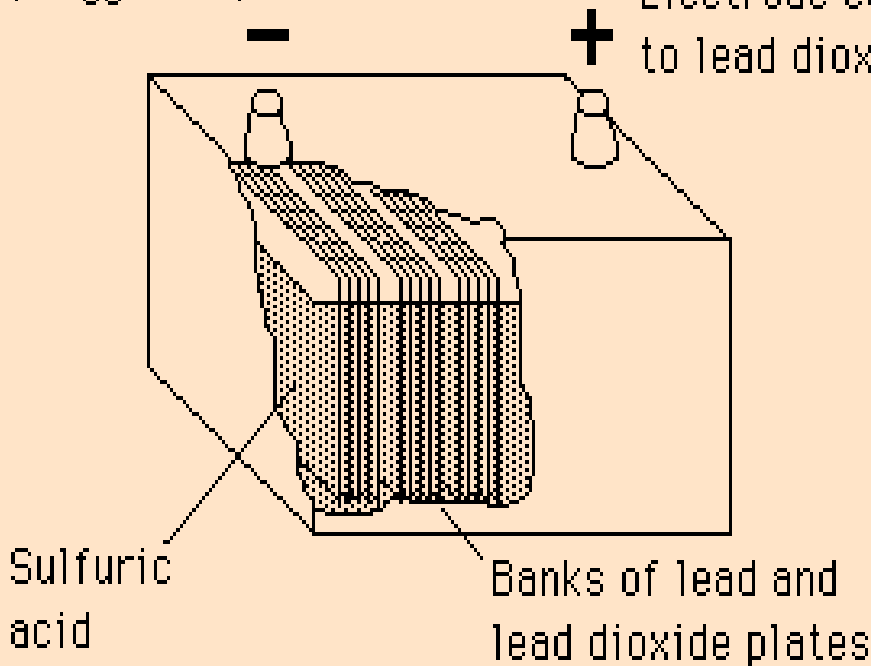

# 4. Chemical Storage

## Fuel Cells

- Direct conversion  
Energy → Electricity
- Burning Fuel?
- High Efficiency
- Applications:  
E.g.: NASA, Viable  
alternative to petrol  
engines.

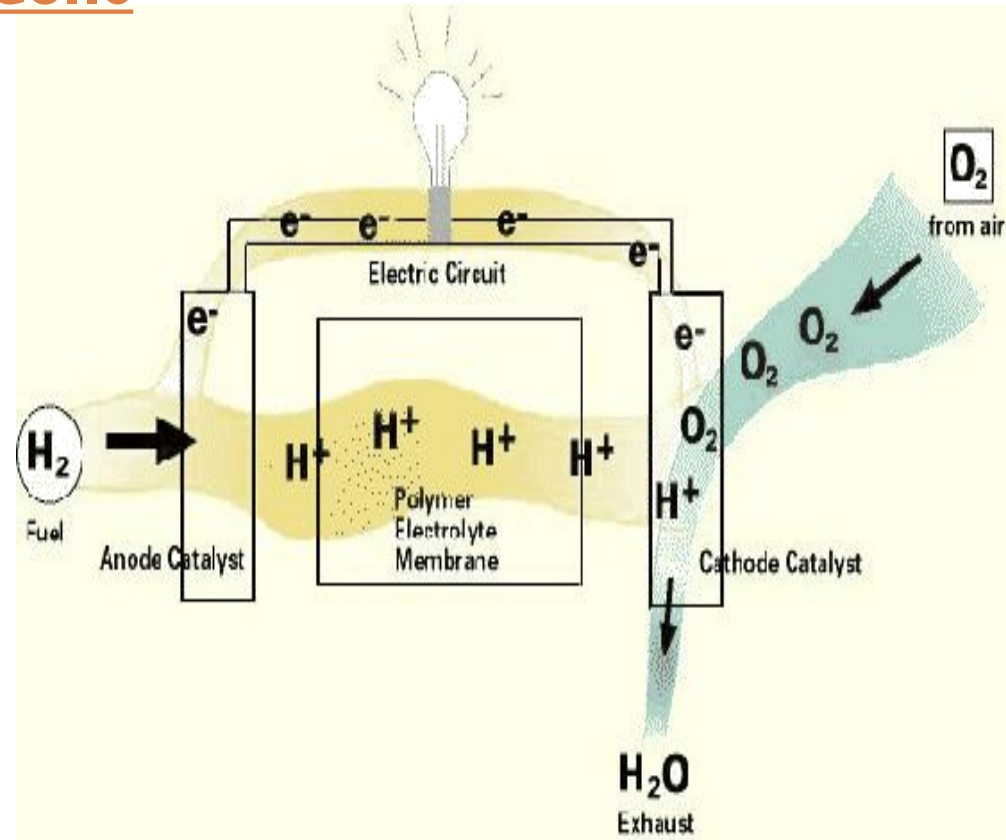

## Advantages:

- No green house gases
- Not much political dependence
- More operating time.

## Disadvantages:

- Storage of Hydrogen due to highly inflammable nature of H<sub>2</sub>.
- High capital cost due to Platinum catalyst used in the process.

# Performance factors for energy storage systems

- Energy capture rate and efficiency.
- Discharge rate and efficiency.
- Dispatchability and load following characteristics.
- Scale flexibility.
- Durability – cycle lifetime.
- Mass and volume requirements – footprint of both weight and volume.
- Safety – risks of fire, explosion, toxicity.
- Ease of materials recycling and recovery.

# Energy storage costs and status

- Capital versus operating costs.
- Current commercial systems :-
  1. pumped hydro (widely deployed: more than 20 GWe USA capacity).
  2. thermal energy storage (water, ice, passive systems common).
  3. chemical energy storage (natural gas, petroleum, solid fuels).
  4. batteries – 1 W to 100 kW scale now common for lead acid.
- future systems :-

(flywheels – supercapacitors – compressed air – fuel cells).

# Storage Challenges for Hybrid Electric Vehicles (HEV)

- Energy Storage for an HEV
- **Batteries**
  - I. Lead-acid.
  - II. Lithium-ion.
  - III. Nickel-metal hydride.
- **Ultracapacitors.**
- **Flywheels**





# Environmental issues for energy storage

## □ Land use :-

- I. inundation caused by hydro projects.
  - II. thermal (hot/cold) island local effects.
  - III. underground storage systems have special geotechnical requirements to insure safe operation  
geotechnical requirements to insure safe operation.
- Materials toxicity disposal and recycle (e.g. batteries).
  - Durability and lifetime of entire system.
  - Emissions during manufacture and operation.

# Energy storage and transmission summary

## □ Range of energy storage:-

- I. from watts to megawatts.
- II. e.g. from small batteries to pumped hydropower.

## □ Modes of energy storage:-

- I. Potential energy ( pumped hydro).
- II. Kinetic ( mechanical flywheels).
- III. Thermal.
- IV. Chemical ( heats of reaction and combustion for biomass, fossil, hydrogen).
- V. Electrical (electrochemical, electrostatic, batteries, supercapacitors)

# Cont.

- Importance of both power and energy density (weight and/or volume).
- Transmission many options but costs increase with distance while performance decreases.
- Environmental Impacts and sustainability issues